

**REDBLADE Pty Ltd**  
**Dextron Heatshrink**  
26 Collingwood St,  
Albion, Qld 4010  
Ph:(07) 32622344  
Fax:(07) 32622074  
email: sales@redblade.com.au  
Web: www.redblade.com.au



Dextron Heatshrink's - One Step L-Bar Shrink Wrapper is great for professionally finished products for both point of sale and ideal for product security.

This machine features one action seal and shrink with easy to operate analogue controls.

Supplied on a mobile stand the One Step L-bar sealer is ideal for printing companies or product that needs to be reworked.

Both PVC or POF centre fold shrink films can be used.

The One Step L-Bar Sealer is also available in other sizes.

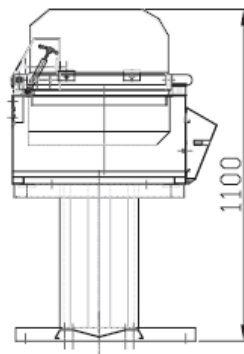
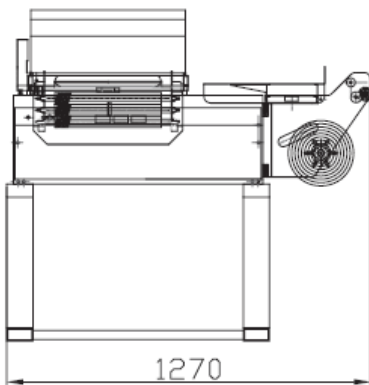

**Power Requirements:**  
240v, single phase, 15amp.

**Machine dimensions:**  
(LxWxH) 1270x730x1100

**Seal Area:**  
420mmx550mm

**Machine Weight:**  
90kg (with stand 108kg)

**Height of working table (on stand):** 920mm

**Max product height capacity:**  
200mm

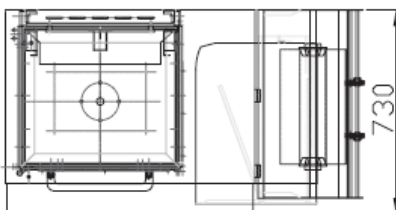

# One Step L-Bar Sealer