

Redblade Pty Ltd

Dextron Heatshrink

MH-FG-2000B Automatic Pallet Stretch Wrapper - Pre-stretch



Operation:

Turn on the power, choose auto mode on the control screen. Pull out suitable film, attach onto the pallet, push star

wrapping is finished.

Characteristics and strong points:

- *adopting PLC and screen controller
- *Photoelectric eye for sensing pallet height
- *Rotary table can reset automatically
- *Soft Start/Stop
- *250% pre-stretch standard/adjustable also
- *Variable speed turntable & film carriage
- *No knife auto film cut

Power Requirements:

240v, single phase, 10 amp.

Machine dimensions: (LxWxH)

2340x1500x2400

Turntable dia.: 1500mm

Turntable Thickness: 85mm

Turntable speed: 0-12 r/min

Capacity: 2000kg

Machine Weight: 700kg (800kg Gross)

Optional: Ramp or Top Platen

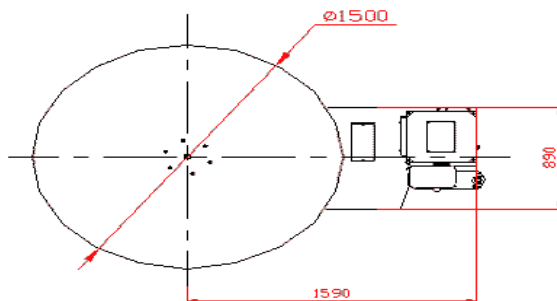
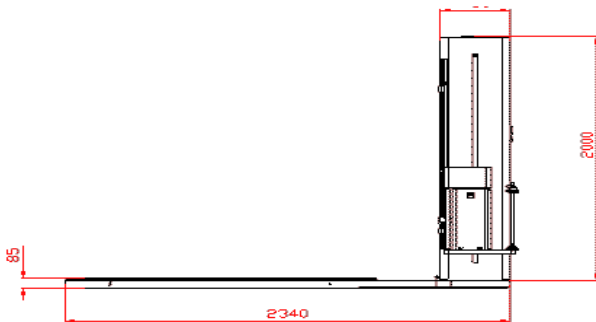

www.redblade.com.au

26 Collingwood St, Albion Queensland 4010

Phone: 07 32622344 Fax: 07 32622074

Email: sales@redblade.com.au